

# Megaplex-4

## Next Generation Multiservice Access Nodes



- Carrier-class multiservice platform: Ethernet services, high speed, low speed, analog voice, data, fiber multiplexing and pseudowire connectivity
- Central solution aggregating Ethernet and TDM services over fiber/copper from RAD CPEs towards SDH/SONET and/or PSN core networks
- MEF CE 2.0 certified, support of MEF applications: Ethernet Private Line (EPL/EVPL), Ethernet Private LAN (EP-LAN/EVP-LAN) and E-TREE, with flexible mapping of user traffic into Ethernet flows
- Distributed network functions virtualization (D-NFV) for rapid rollout of new services and network capabilities
- Certified for IEEE-1613



Central site solution, major building block of RAD's portfolio for service providers, carriers and utilities, Megaplex-4 functions as a carrier-class, TDM and Ethernet aggregator, as well as a high capacity DSO cross connect and next generation multiservice access node. It transports legacy and next-generation services over any infrastructure for seamless migration.

The Megaplex-4 family includes two devices: a larger 10-slot Megaplex-4100 and a compact 4-slot Megaplex-4104.

When deployed as a carrier-class Ethernet aggregator, Megaplex-4 can terminate Ethernet traffic carried over E1/T1/SHDSL/SHDSL.bis/fiber links or native Ethernet copper and fiber, as well as through a VCG in the SDH/SONET circuits. This traffic can then be switched either to a different PDH/TDM trunk or to Ethernet ports.

With RAD's Service Assured Access (SAA) capabilities, Megaplex-4 provides Carrier Ethernet functionalities, such as traffic management (TM), standards-based operations, Administration and Monitoring and Performance Monitoring (OAM&P).

Using pseudowire, Megaplex-4 provides legacy services over packet-switched networks (PSN) making it a fundamental building block in RAD's Service Migration

Hybrid Access solution. Megaplex-4 converts the data stream from TDM/serial modules in the MP-4100/4104 chassis (E1/T1, SHDSL, data or voice ports) into IP or MPLS packets for transmission over Ethernet, IP or MPLS networks.

### MARKET SEGMENTS AND APPLICATIONS

Various users can benefit from the Megaplex-4 solution:

- SDH/SONET customers who need to maximize bandwidth utilization of their network
- Subscribers with mixed Ethernet and TDM services
- Subscribers looking for a future-proof migration path to IP connectivity
- Dual network owners using SDH/SONET for voice, and packet for data.

Its ability to handle a broad range of Ethernet, data and voice services, as well as a large variety of network technologies in a single compact managed node, makes Megaplex-4 an ideal core/edge solution for carriers and service providers. It also provides a perfect fit for large enterprises, utilities and transportation companies that require an efficient way to transport and

provision multiple legacy and next-generation services over their high capacity pipes.

### RESILIENCY

#### Carrier-Class Reliability

Carrier-class service reliability ensures continuous availability and sub-50ms restoration in the event of network outages through system redundancy options, link and path protection schemes and enhanced support for diverse ring topologies.

#### Traffic Duplication

Traffic Duplication, a unique technology available in Megaplex-4, allows networks with mission-critical applications to enhance reliability and performance. It can be used to minimize delay on critical utility applications (such as Teleprotection) by capitalizing on Carrier Ethernet reduced latency at higher speeds. Mission-critical traffic can be transported over a new Carrier Ethernet network running in parallel with the existing SDH/SONET network, while preparing for future, full service migration.

# Megaplex-4

## Next Generation Multiservice Access Nodes

### D-NFV

The D-NFV option adds to Megaplex-4 a built-in standard Intel x86 core that hosts virtual machines providing virtual network functions (VFs) or value-added service capabilities. This new capability provides a quick and easy way to introduce new services and applications with the benefit of function localization at the customer premises.

### MANAGEMENT AND SECURITY

Megaplex-4 offers carrier-class provisioning features, including end-to-end path management, to ensure continuous service availability. Advanced SNMP management capabilities enable Megaplex-4 to control and monitor all network elements: SDH/SONET access and ring units, as well as remote POP and first mile broadband access feeders and CPEs.

## Specifications

### SDH/SONET INTERFACE

#### Number of Ports

2 per CL.2 module (4 per chassis)

#### Protection

Link Protection

- 1+1 unidirectional / bidirectional APS (G.841, Clause 7.1)
- 1+1 bidirectional optimized APS (G.841 Annex B. Linear Multiplex Section (MSP))

Path Protection

- 1+1 unidirectional APS (G.842, Clause 6.2.3) - Ring interworking with a SNCP ring

#### Line Coding

NRZ

#### Connectors

SFP socket

#### Data Rate

STM-4/OC-12: 622.08 Mbps  $\pm$  4.6 ppm

STM-1/OC-3: 155.52 Mbps  $\pm$  4.6 ppm

### Compliance

SDH: ITU-T G.957, G.798, G.783

SONET: ANSI T1.105-1995, GR-253-core

GFP (Generic Framing Procedure): ITU-T

G.7041, ANSI T1-105.02, framed mode;

LCAS (Link Capacity Adjustment Scheme):

ITU-T G.7042

### Framing

SDH: ITU-T G.707, G.708, G.709

SONET: GR-253-core

### GIGABIT ETHERNET INTERFACE

#### Number of Ports

2 per CL.2 module (4 per chassis)

#### Data Rate

10/100/1000 Mbps

Autonegotiation (copper interface only)

#### Connectors (per port)

RJ-45, shielded

SFP socket

#### Maximum Frame Size

9600 bytes (for max. frame sizes supported by different I/O modules, see individual data sheets)

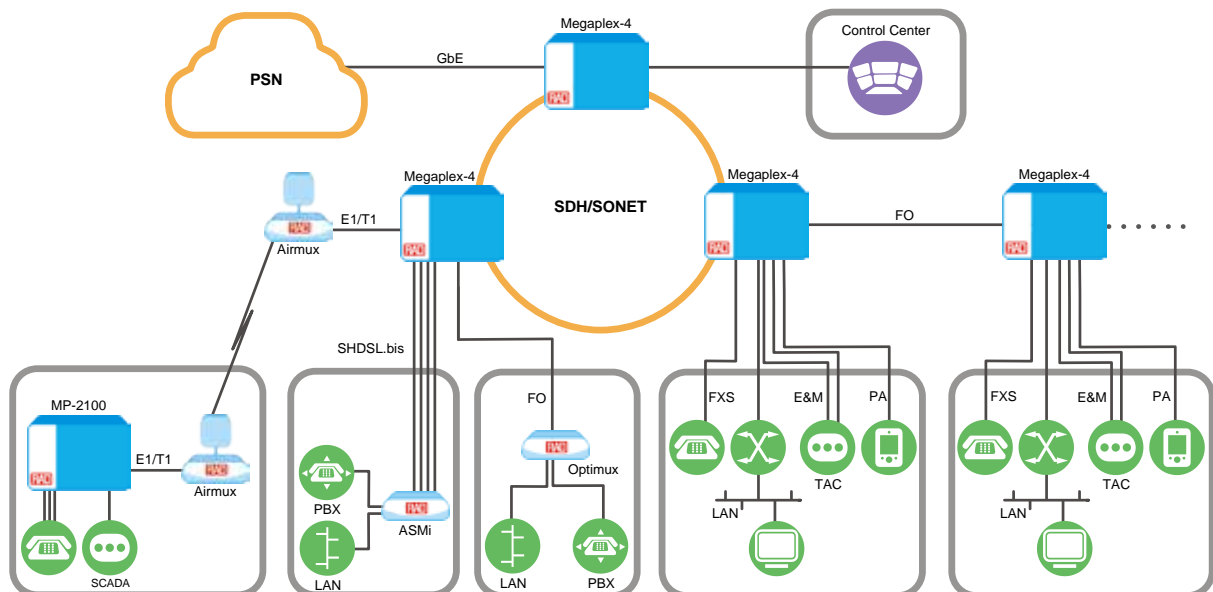

Figure 1. Megaplex-4 as Multiservice Platform with Diverse Interfaces and Access Topologies for U&T Market Segment

**Compliance**

CE 2.0, MEF 6 (E-Line – EPL and EVPL, E-LAN – EPLAN and EVPLAN, E-TREE), MEF 10, MEF 9, MEF 8 MEF 14, MEF 20, IEEE 802.3, 802.3u, 802.1q, 802.1p, 802.1X, 802.3ad, 802.3-2005, 802.3ah, 802.1ag, ITU-T Y.1731, G.8032

**Service**

EPL and EVPL (flow-based)  
E-LAN (EP-LAN and EVP-LAN), bridge-based  
E-TREE (bridge-based)

**Bandwidth Profile**

CIR/CBS, EIR/EBS per flow

**MAC Address Table**

Up to 16K entries with configurable limiter

**Operation Mode**

VLAN-aware, VLAN-unaware

**OAM**

IEEE 802.3ah  
IEEE 802.1ag: CCM, Loopback, link trace, MEP  
ITU-T Y.1731, Frame-loss, Frame-delay, Frame-delay-variation, PM

**Protection**

Link aggregation supporting link and equipment protection

Hitless Switching Redundancy in Ring topology according to IEC 62439-3  
RSTP on network ports (CL.2/A)

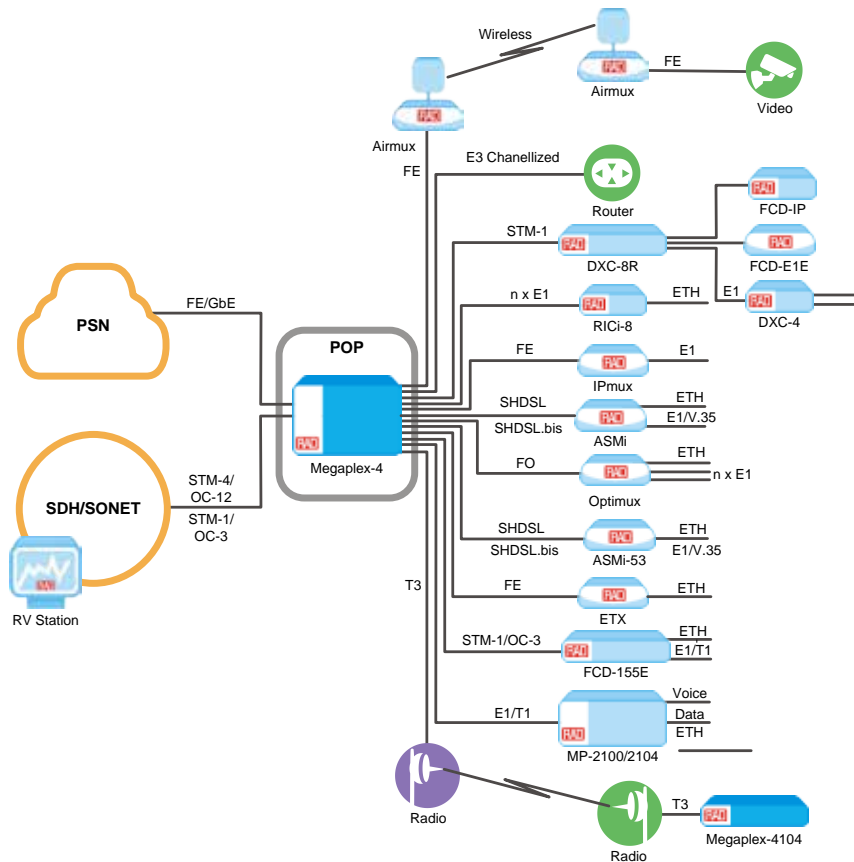

Figure 2. Megaplex-4 as a Central Site Aggregator for different RAD CPEs, Ethernet and TDM Aggregator for SDH/SONET and PSN

**Forwarding Mode**

Flow-based, bridge-based

Ethernet Ring Protection Switching complying with ITU-T G.8032

# Megaplex-4

## Next Generation Multiservice Access Nodes

### SDH/SONET AND GBE SFPS

For full details, see the [SFP/XFP Transceivers data sheet](#) at [www.rad.com](http://www.rad.com)

- All SFPs listed for STM-4/OC-12 and STM-1/OC-3 are supported by the SDH/SONET link except for those with external calibration
- All SFPs listed for GbE are supported by the GbE link, except for those with external calibration and SGMII.

**Note:** *It is strongly recommended to order this device with **original RAD SFPs installed**. This will ensure that prior to shipping, RAD has performed comprehensive functional quality tests on the entire assembled unit, including the SFP devices. RAD cannot guarantee full compliance to product specifications for units using non-RAD SFPs.*

### I/O MODULES

See *Table 1*. For detailed description, see separate data sheets.

### MANAGEMENT

#### Management Options

CLI  
RADview management and VF orchestration suite  
Standalone Shelf View application

#### Tools

Telnet/SSHv2, SNMPv2, SNMPv3, SFTP  
RADIUS, TACACS+

### Connectivity

Out-of-band

Inband, via the STM-4/OC-12/STM-1/OC-3 links or over a dedicated timeslot in any E1/T1 or SHDSL link or via any of the user Ethernet ports

### Ethernet Management Port

Interface: 10/100BaseT  
Connector: RJ-45

### Control Port

Interface: RS-232/V.24 (DCE)

Connectors:

- CL.2: DB-9
- CL.2/4104: MINI-USB

Baud rate: 9.6, 19.2, 38.4, 57.6, 115.2

### SECURITY

Port-Based Network Access Control (PNAC) per IEEE 802.1X-2100:

- Port-based authorization
- Supplicant for CL.2/A GbE ports
- Authenticator applicable on M-ETH modules and VS modules with Ethernet ports

MAC-based authentication support (802.1X-based)

License-based (per CL) MACsec per IEEE 802.1AE-2006 and 802.1AEbn-2011 (128/256-bit)

- Data Encryption and integrity protection hop-by-hop
- Key exchange based on 802.1X
- Special ordering option for 2GbE ports with MACsec on CL.

### TIMING

#### Clock Sources

Users can define the following clock sources:

- Recovered from the STM-4/OC-12/STM-1/OC-3 interface, including automatic selection, based on SSM (Synchronization Status Messaging)
- Sync-E clock, recovered from the GbE interface (CL.2/A modules only)
- Internal crystal free-running oscillator-based clock
- Derived from the Receive clock of a specified user port
- Adaptive clock recovered (ACR) from a pseudowire circuit
- Clock distribution mechanism (SSM-like) over E1 TS0 interoperable with Nokia proprietary timing mechanism.

#### Station Clock

Bit rate:

- 1.544 Mbps (T1) (AMI)
- 2.048 Mbps (E1) (AMI)
- 2.048 MHz squarewave

Connector: RJ-45

Table 1. Megaplex-4 I/O Modules

Module	Description	Operating in MP-2100/2104
System Modules		
CL.2	Common Logic module	
CL.2/A	Common Logic module, Carrier Ethernet class	
PS	AC or DC power supply module	
I/O Modules (in alphabetical order of names)		
ACM	Alarm and diagnostics module with four outbound relays	Yes
ASMi-54C	8-port SHDSL.bis module with 2 Ethernet ports	
ASMi-54C/N	8-port SHDSL/SHDSL.bis module with 2 Ethernet ports and 8 E1 ports	
D-NFV	Distributed network functions virtualization module	
HS-6N, HS-12N	6- or 12-port n x 64 kbps high speed module	Yes
HS-703	4-channel Codirectional data module	Yes
HSF-2	2-port fiber optic teleprotection interface module	Yes
HS-RN	4-port sub-DSO low speed module	Yes
HS-S	4-channel ISDN "S"-interface module	Yes
LS-6N, LS-12	6- or 12-port low speed modules	Yes
M-ETH	8-port GbE interface module	
M16E1, M16T1	16-port E1 or T1 modules	
M8E1, M8T1	8-port E1 or T1 modules with 3 Ethernet ports	
M8SL	8-port SHDSL E1 module with 3 Ethernet ports	
MPW-1	TDM pseudowire access gateway with 3 Ethernet ports	
OP-108C	Dual 4 x E1 and Ethernet fiber multiplexer module	
Ringer-2100R Ringer-4104R	DC power supply module for DC feed and up to 32 voice channel ring voltages for Megaplex-4100/Megaplex-4104	
SH-16	16-port SHDSL.bis EFM module with optional E1 and PW support	
T3	T3 multiplexer module	
TP (Teleprotection)	4-input, 8-output port teleprotection module with selectable trip voltage	
VC-4/4A/8/8A/16	4/8/16-port FXS/FXO/E&M PCM and ADPCM analog voice modules	Yes
VC-4/OMNI	4-port PCM omnibus voice module	Yes
VC-6/LB	6-port PCM voice module for local battery telephones	Yes
VS-12	12-port serial module with 2 Ethernet ports	
VS-6/BIN	6-port serial module with 8 binary in/out command ports and 1 Ethernet port	
VS-6/C37	6-port serial module with 2 fiber optic C37.94 ports and 1 Ethernet port	
VS-6/E&M	6-port serial module with 4 E&M voice ports and 1 Ethernet port	
VS-FXS/E&M	Voice module with 4 E&M ports and 8 FXS ports	
VS-6/FXO	6-port serial module with 8 FXO voice ports and 1 Ethernet port	
VS-6/FXS	6-port serial module with 8 FXS voice ports and 1 Ethernet port	
VS-16E1T1	16-port E1/T1 module with PW or EOP support	
VS-6/E1T1	6-port serial module with 8 E1/T1 ports, 1 Ethernet port and PW support	
<b>Note:</b> For specific HW/SW versions of Megaplex-210x modules supported by the Megaplex-4 chassis, please contact your local RAD partner.		

### DIAGNOSTICS

#### Alarm Relay

1 inbound relay – RS-232 levels (dry contact)

2 outbound relays triggered by major/minor alarms

Operation: normally open, normally closed, using different pins

Connectors:

- CL.2: DB-9, female
- CL.2/4104: 9-pin, flat

### GENERAL

#### Environment

##### MP-4100

Operating temperature:

- Regular: -10°C to 55°C (14°F to 131°F)
- IEEE-1613 “no-fan” compliant system and modules: -20°C to 55°C (-4°F to 131°F)

Storage temperature: -20°C to +70°C (-4°F to +160°F)

Humidity: up to 95%, non-condensing

##### MP-4104

Operating temperature:

-10°C to 55°C (14°F to 131°F)

Storage temperature: -20°C to +70°C (-4°F to +160°F)

Humidity: up to 95%, non-condensing

**Note:** Actual operating temperature range is determined by the specific modules installed in the chassis. For extended operating temperature ranges, contact your local RAD Business Partner.

#### Power Supply Input

##### MP-4100

AC: 115 /230 VAC (allowed range: 85 to 264 VAC), 50/60 Hz

HVDC support: 100 to 360 VDC

DC:

48 VDC (allowed range: -36 to -56 VDC)

24 VDC (allowed range: 20 to 36 VDC)

Selectable ground reference or floating ground

##### MP-4104

AC: 90 to 264 VAC, 50/60 Hz

HVDC support: 110 to 300 VDC

DC: 48 VDC (allowed range: -36 to

-56 VDC); selectable ground reference or floating ground

#### Maximum Input Power

##### MP-4100

315W + power supplied for ring and feed voltage

##### MP-4104

200W + power supplied for ring and feed voltage

##### MP-4104

160W + power supplied for ring and feed voltage

#### Output Power (max)

##### MP-4100

- Regular: 250W
- IEEE-1613 “no-fan” compliant system and modules: 175W

##### MP-4104

160W

#### Power Consumption (per CL, max)

27.75 W

#### Physical

##### MP-4100 (4U-high)

2 power supply module slots

2 CL. 2 module slots

10 slots for I/O modules

Height: 18 cm (7 in) (4U)

Width: 44 cm (17 in)

Depth (regular): 33 cm (13 in)

Depth (IEEE-1613-compliant): 37 cm (14.6 in)

Weight: 15.3 kg (33.8 lb) max. (fully loaded chassis)

##### MP-4104 (2U-high)

2 power supply module slots

2 CL.2 module slots

4 slots for I/O modules

Height: 9 cm (3.5 in) (2U)

Width: 44 cm (17 in)

Depth: 33 cm (13 in)

Weight: 7.54 kg (16.6 lb) (fully loaded chassis)

**Note:** The chassis weight depends of the type and number of installed modules.

##### CL.2 Module

Height: 17.3cm (6.8 in)

Width: 4.5 cm (1.8 in)

Depth (regular): 32.5cm (12.8 in)

Depth (IEEE-1613-compliant): 35 cm (13.8 in)

Max weight (regular): 630 g (1.3 lb)

Max weight (IEEE-1613-compliant): 2030 g (2.27 lb)

##### CL.2/4104 Module

Height: 17.3cm (6.8 in)

Width: 2.5 cm (1 in)

Depth: 32.5cm (12.8 in)

Max weight: 540 g (1.2 lb)



## Megaplex-4

## Ordering

Megaplex-4 must be ordered with the RADcare Basic Plus service package for one year.

## RECOMMENDED CONFIGURATIONS

**MP-4100-2/48R/622GBEASFPR**  
**MP-4104-2/48R/622GBEASFPR**

Megaplex-4100 or Megaplex-4104 chassis with dual 48 VDC PS modules and dual CL.2 modules, Carrier-Ethernet class with SDH/SONET SFP sockets and GbE SFP sockets

**MP-4100-2/230R/622GBEASFPR**  
**MP-4100-2/115R/622GBEASFPR**  
**MP-4104-2/ACR/622GBEASFPR**

Megaplex-4100 or Megaplex-4104 chassis with dual AC PS modules and dual CL.2 modules, Carrier-Ethernet class, with SDH/SONET SFP sockets and GbE SFP sockets

**MP-4100-2/48R/DSOR**  
**MP-4104-2/48R/DSOR**

Megaplex-4100 or Megaplex-4104 chassis with dual 48 VDC PS modules and dual CL.2 modules without SDH/SONET and GbE links

**MP-4100M-CL.2/622GBEASFP**  
**MP-4104M-CL.2/622GBEASFP**

Megaplex-4100 or Megaplex-4104 CL.2 module, Carrier Ethernet class with SDH/SONET SFP sockets and GbE SFP sockets

**MP-4100M-CL.2/GBEASFP**  
**MP-4104M-CL.2/GBEASFP**

Megaplex-4100 or Megaplex-4104 CL.2 module, Carrier Ethernet class with GbE SFP sockets

**MP-4100M-CL.2/GBEAPSFP**  
**MP-4104M-CL.2/GBEAPSFP**

Megaplex-4100 or Megaplex-4104 CL.2 module, Carrier Ethernet class with GbE SFP sockets and 2 GbE MACsec engines

**MP-4100M-CL.2/GBEAPUTP**  
**MP-4104M-CL.2/GBEAPUTP**

Megaplex-4100 or Megaplex-4104 CL.2 module, Carrier Ethernet class with GbE copper interface and 2 GbE MACsec engines

**MP-4100M-CL.2/DSO**  
**MP-4104M-CL.2/DSO**

Megaplex-4100 or Megaplex-4104 CL.2 module for E1/T1/DSO cross-connect

**MP-4100M-CL.2/622GBEASFP/155SK**  
**MP-4104M-CL.2/622GBEASFP/155SK**

Megaplex-4100 or Megaplex-4104 CL.2 module, Carrier-Ethernet class, with STM-1/OC-3 SFP sockets and GbE SFP sockets, can be activated for STM-4/OC-12 by purchasing a SW license key (MP-4100-LIC/622SK or MP-4104-LIC/622SK)

## SPECIAL CONFIGURATIONS

Please contact your local RAD partner for additional configuration options.

*Note: CLI prompt and/or SDH/SONET path trace string can be changed (factory-set) according to the customer request.*

## SUPPLIED ACCESSORIES

**Megaplex-4100 (only with MP-4100-2)****CBL-SP-9/SH**

Dual DB-9 to single DB-9 control cable

**CBL-MP-4100/AR/OPEN/2M**

Open-ended alarm cable

**RM-MP-MX-23/19**

Hardware kit for mounting one MP-4100 unit into both 19-inch and 23-inch racks

**Megaplex-4104 (only with MP-4104-2)****CBL-MUSB-DB9F**

Mini-USB to DB-9 control cable

**CBL-MP-4104/AR/OPEN/2M**

Open-ended alarm cable

**RM-42**

Hardware kit for mounting one MP-4104 unit in a 19-inch rack

## OPTIONAL ACCESSORIES

**MP-2100-RM-ETSI/19**

Hardware kit for mounting one MP-4100 unit into ETSI racks (fits also 10-inch racks)

*Note: This RM can be either ordered in addition to RM-MP-MX-23/19 or received for free instead of it.*

**RM-51**

Thermal isolation panel for mounting two fanless MP-4100 devices in 19" rack

**RM-42-CM**

Hardware kit for mounting one MP-4104 unit in a 19-inch rack with cable management

**WM-42**

Hardware kit for installing MP-4104 unit on a wall

**WM-42-CM**

Hardware kit for installing a MP-4104 unit on a wall with cable management

## International Headquarters

24 Raoul Wallenberg Street  
Tel Aviv 69719, Israel  
Tel. 972-3-6458181  
Fax 972-3-6498250, 6474436  
E-mail market@rad.com

## North American Headquarters

900 Corporate Drive  
Mahwah, NJ 07430, USA  
Tel. 201-5291100  
Toll free 1-800-4447234  
Fax 201-5295777  
E-mail market@radusa.com